

ATTENTION
All information contained in this document is the exclusive property of **KLEMSAN** and may neither be used nor disclosed without its prior written consent. Parts manufactured to this drawing may not be given to third parties without the prior written consent of **KLEMSAN**.
DO NOT SCALE REVISE ONLY ON CAD NO MODIFICATIONS PERMITTED

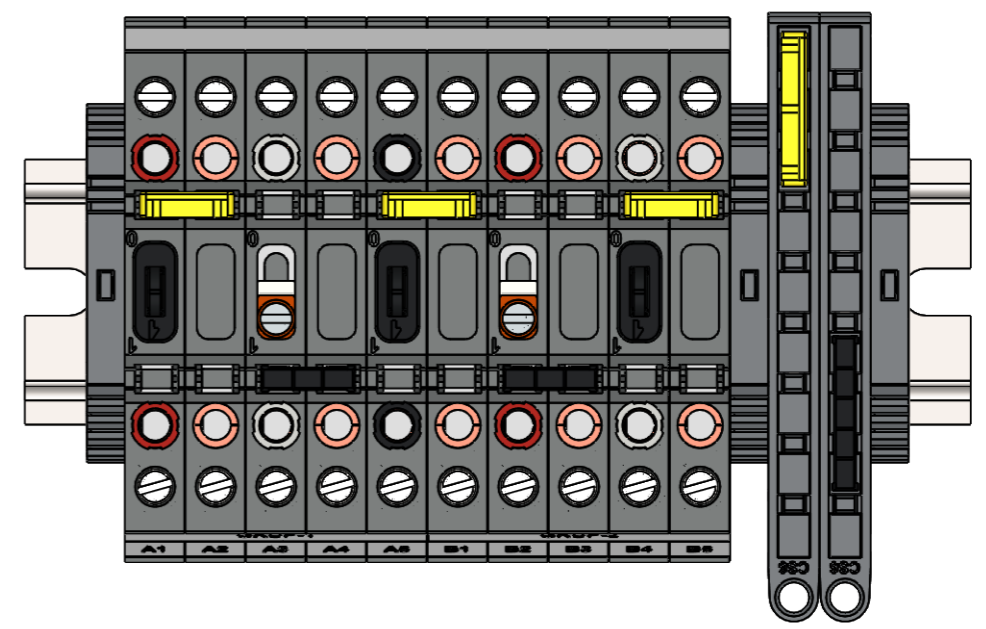
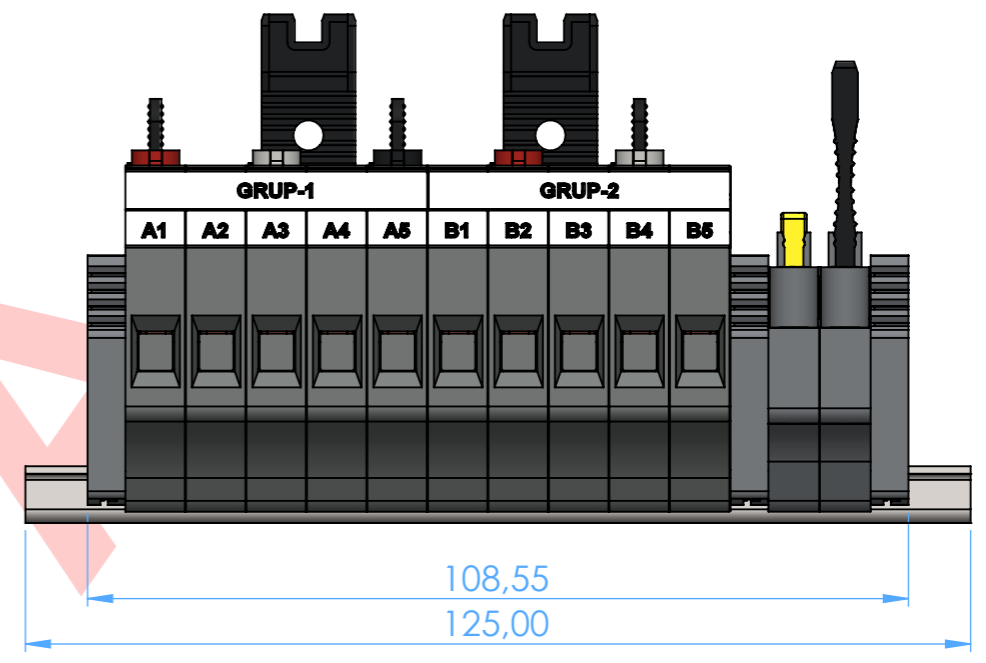
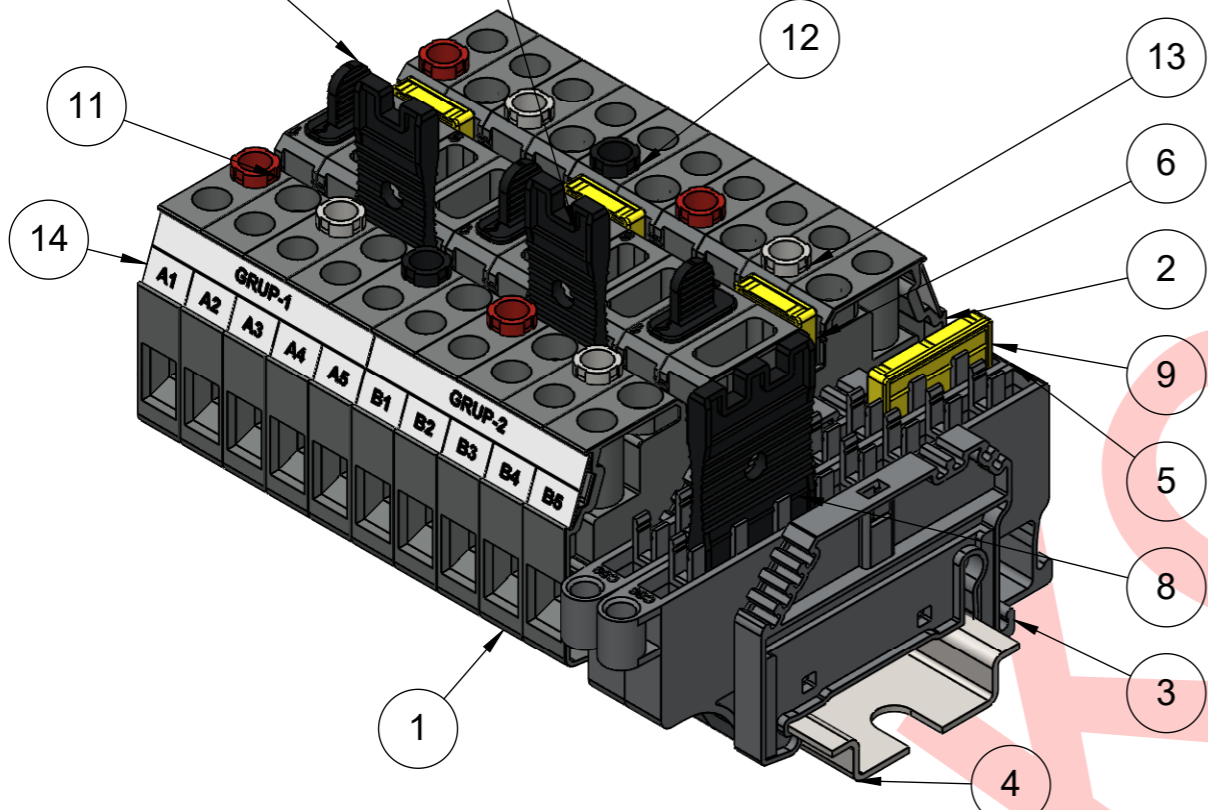
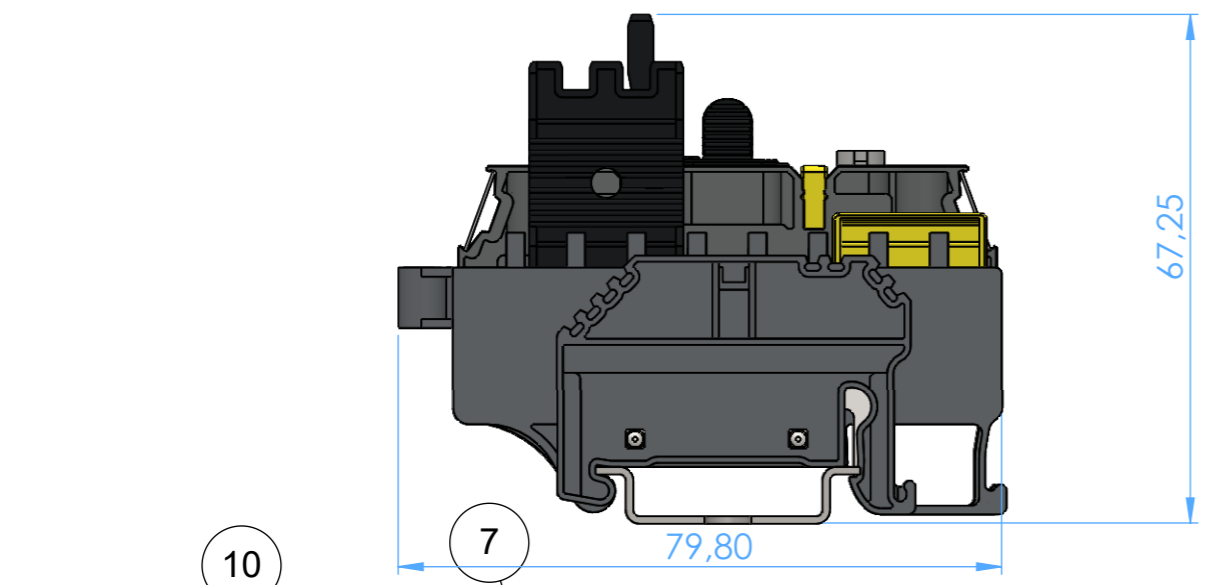

NO.	QTY.	PART NAME	PART NUMBER
14	2	SERIT ETIKET 11,2 (80mm)	2.8.0.4.000121
13	4	WGO 6/NM KP (BEYAZ)	0.1.0.0.469066
12	2	WGO 6/NM KP (SIYAH)	0.1.0.0.469065
11	4	WGO 6/NM KP (KIRMIZI)	0.1.0.0.469064
10	3	WGO 6/NM PLASTIK KILIT (SIYAH)	0.1.0.0.469075
9	1	CS 6/3	0.1.0.0.470123
8	1	SCS 6/2	0.1.0.0.470173
7	2	SCS 6/2	0.1.0.0.470172
6	3	CS 6/2	0.1.0.0.470122
5	2	ATCS 6 GRI	0.1.0.0.499559
4	1	MR35x7,5 RAY 125 MM (SLOTLU) (CINKO KAPLI)	2.7.3.1.010212
3	3	KD 8 (GRI)	0.1.0.0.495229
2	5	WGO D6/NM (GRI)	0.1.0.0.309619
1	5	WGO 6/NM (GRI)	0.1.0.0.309609

GENERAL TOLERANCE	0...15 mm	15...30 mm	30... mm
±	±0,05	±0,10	±0,15
∇	∇0,10	∇0,15	∇0,20
∇	∇0,15	∇0,20	∇0,30

PROJE GRUBU/TIPI PRODUCT GROUP/TYPE	PARÇA/MONTAJ ADI PART/ASSEMBLY NAME	RESİM NO DRAWING NO	REV. NO	ANTET FORMAT
OZEL SETLER ONAYLANMIS_SETLER	WGO_6 SET	0.0.0.9.00246	00	A3

DİKKAT
* İlk ürün onayında (FA) ve her siparişte balonlu ölçüler ve teknik istisnaları (Kaplama, Serifik vs.) ait ölçüm raporu gönderilecektir.
ATTENTION
* Supplier must send test report for dimensions and technical requirements (Coating, Hardness, etc) at FAI and with every order

ADI - SOYADI NAME - SURNAME	TARİH DATE	İMZA SIGN	KAPLAMA PLATED	SERTLİK (Hv) HARDNESS (Hv)	AĞIRLIK (KG) MASS (KG)
G.GÜLSEVER	07.01.2019				0.30338607
S.SERVÜZ	07.01.2019		MALZEME MATERIAL	MALZEME STOK KODU MATERIAL STOCK CODE	
M.AKAY	07.01.2019				

Klemsan®
ELEKTRİK ELEKTRONİK SAN. ve TİC. A.Ş.
www.klemsan.com.tr