

ATTENTION  
 All information contained in this document is the exclusive property of KLEMSAN and may neither be used nor disclosed without its prior written consent. Parts manufactured to this drawing may not be given to third parties without the prior written consent of KLEMSAN.  
 DO NOT SCALE REVISE ONLY ON CAD NO MODIFICATIONS PERMITTED

DİKKAT  
 \* İlk ürün onayında (FA) ve her siparişte balonlu ölçüler ve teknik istisnalar (Kaplama, Serilik vs.) ölçüm raporu gönderilecektir.  
 \* Supplier must send test report for dimensions and technical requirements (Coating, Hardness, etc) at FAI and with every order

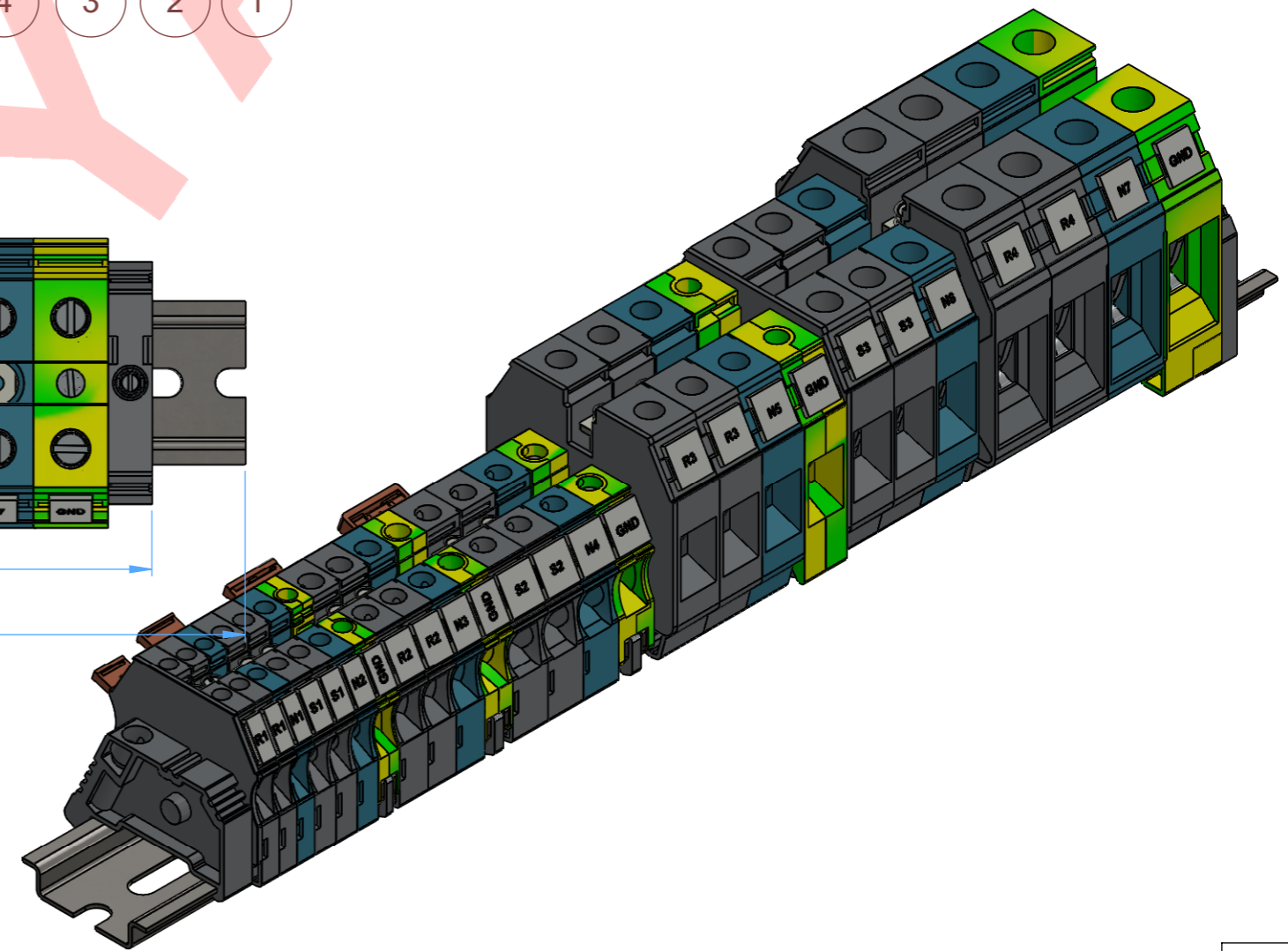
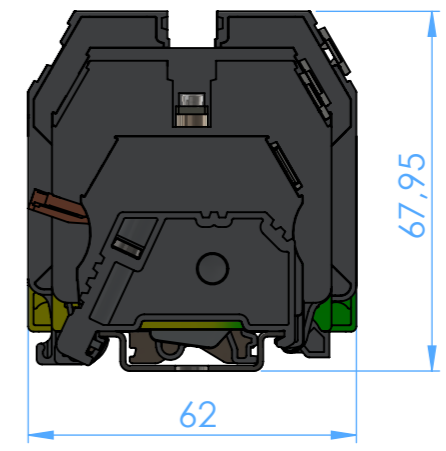
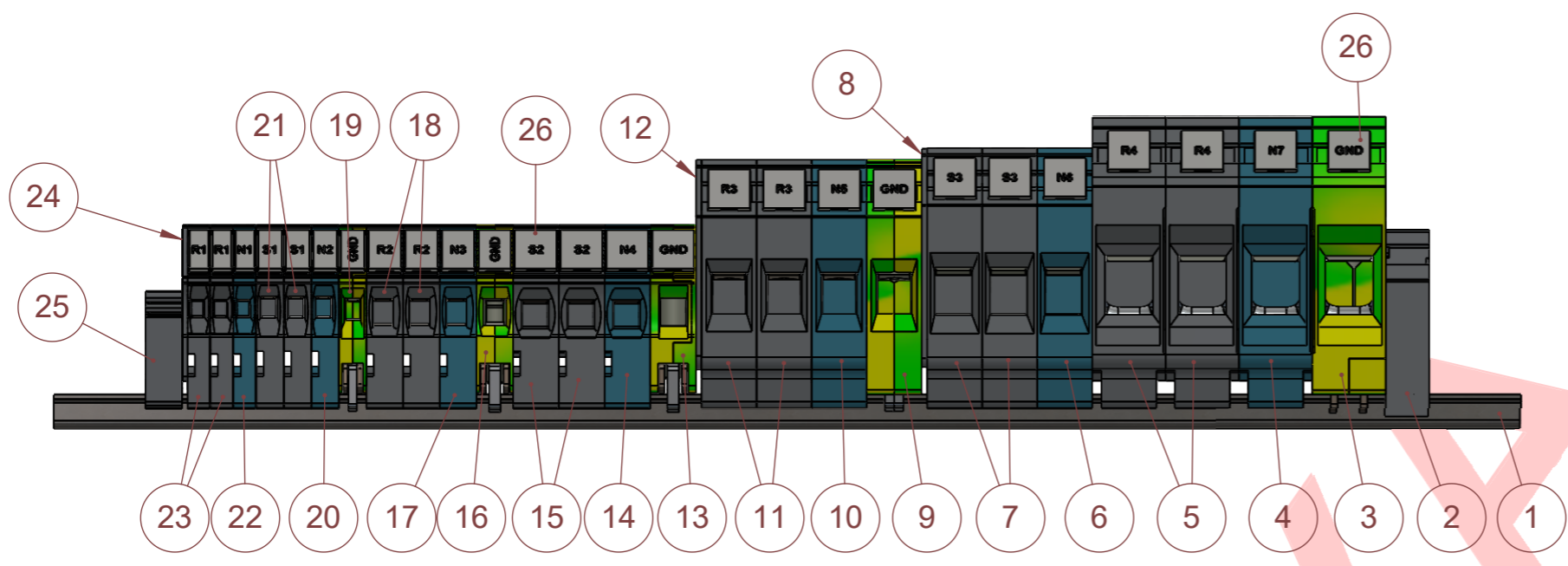

GENERAL TOLERANCE	PROJE GRUBU/TIPI PRODUCT GROUP/TYPE	PARÇA/MONTAJ ADI PART/ASSEMBLY NAME	RESİM NO DRAWING NO	REV. NO	ANTET FORMAT				
0...15 mm	OZEL SETLER ONAYLANMIS_SETLER	AVK SERISI SET	0.0.0.9.00049	00	A3				
15...30 mm									
30...mm									
	ADI - SOYADI NAME - SURNAME	TARİH DATE	İMZA SIGN	KAPLAMA PLATED	SERTLİK (Hv) HARDNESS (Hv)	AĞIRLIK (KG) MASS (KG)	<b>Klemsan®</b> ELEKTRİK ELEKTRONİK SAN. ve TİC. A.Ş. www.klemsan.com.tr	MIKTAR QUANTITY	SAYFA NO PAGE NR
	CİZEN DRAWN BY	G.GÜLSEVER	27.11.2018			0.96467674			
	KONTROL CONTROL	S.SERVÜZ	27.11.2018	MALZEME MATERIAL	MALZEME STOK KODU MATERIAL STOCK CODE				
	ONAY APPROVAL	M.AKAY	27.11.2018						
	ÖLÇEK SCALE	1:5							

DOSYA YOLU :C:\PDMView\KLEMSAN\_MS\ELEKTROTEKNİK\PROJELER\OZEL\_SETLER\ONAYLANMIS\_SETLER\

ATTENTION  
All information contained in this document is the exclusive property of KLEMSAN and may neither be used nor disclosed without its prior written consent. Parts manufactured to this drawing may not be given to third parties without the prior written consent of KLEMSAN.  
DO NOT SCALE REVISE ONLY ON CAD NO MODIFICATIONS PERMITTED

DİKKAT  
\* İlk ürün onayında (FA) ve her siparişte balonlu ölçüler ve teknik istelere (Kaplama, Serilik vs.) ait ölçüm raporu gönderilecektir.  
ATTENTION  
\* Supplier must send test report for dimensions and technical requirements (Coating, Hardness, etc) at FAI and with every order

KOP

NO.	QTY.	PART NAME	PART NUMBER
39	1	UK 35/2 RDS _ AVK 35RDS	0.1.0.0.480212
38	2	UK 16/2 _ AVK 16	0.1.0.0.474162
37	1	UK 10/2 _ AVK 10	0.1.0.0.474152
36	1	UK 6/2 _ AVK 6	0.1.0.0.474142
35	1	UK 4/2 _ AVK 4	0.1.0.0.474132
34	1	UK 2,5/2 _ AVK 2,5	0.1.0.0.474122
33	1	TKO 10/2 - AVK 10 / ASK 4	0.1.0.0.476292
32	1	TKO 6/2 - AVK 6	0.1.0.0.476282
31	1	TKO 4/2 - AVK 4	0.1.0.0.476272
30	1	TKO 2,5/2 - AVK 2,5	0.1.0.0.476262
29	3	DGO 10 X 5 (OZEL) BEYAZ	0.1.0.0.505350
28	4	DGO 10 X 6 (OZEL) BEYAZ	0.1.0.0.505360
27	4	DO 10x8 (OZEL BASKILI)	0.1.0.0.505420
26	15	DO 10x10 (OZEL BASKILI)	0.1.0.0.505440
25	1	KD 3 (GRI)	0.1.0.0.495049
24	1	NPP / AVK 2,5-10 GRI	0.1.0.0.444120
23	2	AVK 2,5 GRI	0.1.0.0.304120
22	1	AVK 2,5 MAVI	0.1.0.0.304121
21	2	AVK 4 GRI	0.1.0.0.304130
20	1	AVK 4 MAVI	0.1.0.0.304131
19	1	AVK 2,5-4TK (MONTAJ)	0.1.0.0.334450
18	2	AVK 6 GRI	0.1.0.0.304140
17	1	AVK 6 MAVI	0.1.0.0.304141
16	1	AVK 6TK	0.1.0.0.334460
15	2	AVK 10 GRI	0.1.0.0.304150
14	1	AVK 10 MAVI	0.1.0.0.304151
13	1	AVK 10TK	0.1.0.0.334470
12	1	NPP/AVK 16 RD GRI	0.1.0.0.444170
11	2	AVK 16 RD GRI	0.1.0.0.304240
10	1	AVK 16 RD MAVI	0.1.0.0.304241
9	1	AVK 16T RD	0.1.0.0.334200
8	1	NPP / AVK 25RD GRI	0.1.0.0.450250
7	2	AVK 25 RD (GRI)	0.1.0.0.304290
6	1	AVK 25 RD (MAVI)	0.1.0.0.304291
5	2	AVK 35 RDS (GRI)	0.1.0.0.304580
4	1	AVK 35 RDS (MAVI)	0.1.0.0.304581
3	1	AVK 35 TRDS	0.1.0.0.334240
2	1	KD 7 (GRI)	0.1.0.0.495219
1	1	MR35x7,5 RAY 320 MM (SLOTLU) (CINKO KAPLI)	2.7.3.1.007612

GENERAL TOLERANCE	PROJE GRUBU/TIPI PRODUCT GROUP/TYPE	PARÇA/MONTAJ ADI PART/ASSEMBLY NAME	RESİM NO DRAWING NO	REV. NO	ANTET FORMAT				
0...15 mm 15...30 mm 30... mm	OZEL SETLER ONAYLANMIS_SETLER	AVK SERISI SET	0.0.0.9.00049	00	A3				
	ADI - SOYADI NAME - SURNAME	TARİH DATE	İMZA SIGN	KAPLAMA PLATED	SERTLİK (Hv) HARDNESS (Hv)	AĞIRLIK (KG) MASS (KG)	<b>Klemsan®</b> ELEKTRİK ELEKTRONİK SAN. ve TİC. A.Ş. www.klemsan.com.tr	MIKTAR QUANTITY	SAYFA NO PAGE NR
	CİZEN DRAWN BY	G.GÜLSEVER	27.11.2018			0.96467674			
	KONTROL CONTROL	S.SERVÜZ	27.11.2018		MALZEME MATERIAL	MALZEME STOK KODU MATERIAL STOCK CODE			
	ONAY APPROVAL	M.AKAY	27.11.2018						
	ÖLÇEK SCALE	1:5							2/2

DOSYA YOLU : C:\PDMView\KLEMSAN\_MS\ELEKTROTEKNİK\PROJELER\OZEL\_SETLER\ONAYLANMIS\_SETLER\